



Operating Manual

Information in this document is subject to change without notice and does not represent a commitment on the part of Advanced Systems and Designs, Inc. No part of this manual may be reproduced or transmitted in any form or by any means, electronic or mechanical, including photocopying and recording, for any purpose without the express written permission of ASD.

The ASD and GageMux® logos are registered trademarks of Advanced Systems and Designs, Inc.

Copyright © Advanced Systems and Designs, Inc., 1984-2004. All rights reserved.

Printed and bound in the United States of America.

Document No. 10040PF

Advanced Systems and Designs, Inc.

2142 Pontiac, Suite 202

Auburn Hills, MI 48326

Phone: (248) 370-9919

Fax: (248) 370-9921

Email: support@spcanywhere.com

Website: <http://www.spcanywhere.com>

GageMux®

4 Input Gage Interface



Operating Manual

Table of Contents

Table of Contents.....	iv
Introduction.....	1
Features.....	2
Included Items.....	2
System Requirements.....	3
GageMux® Quick Start.....	4
Basic Operation	5
Configuration and Setup.....	5
Output String Format	6
Foot Switch Operation	8
Normal and MIN/MAX/TIR Modes	9
Channel Number.....	9
Flow Mode.....	9
DIP Switch Settings.....	10
Host Commands.....	15
Warranty.....	16
Tech Support.....	16
Revision History	16

Introduction

The GageMux® is a device which allows you to connect up to four (4) digital gages to a single RS-232 serial port on any desktop computer, notebook computer, printer, or other serial device.

The GageMux® will work with gages that have digital outputs compatible with Mitutoyo digital gages. Gages available from Chicago Dial, Federal, Ono Sokki, and many others manufacturers, have digital outputs compatible with Mitutoyo digital gages. Please contact Advanced Systems & Designs, Inc. for a complete list of over 300 compatible gages.

The GageMux® is configured through internal DIP switches or commands from a host computer. These commands include:

- Request a reading from a channel.
- Change the setup of a channel.
- Change the output string mode.
- Change the foot switch mode.
- Reset the GageMux®.

Readings are initiated by pressing a read button on the gage, pressing a remote read switch inserted into the foot switch jack, or a host command.

Follow the instructions in this guide to:

- Configure the GageMux® to communicate with your gages in the desired mode.
- Connect the GageMux® to your gages or SmartCables.™
- Interface the GageMux® to your computer, and assist in the configuration of your SPC software.

Features

- Rugged design, built to withstand harsh shop-floor conditions.
- Support for gages from over 300 different manufacturers.
- Two operating modes, Static (Normal) mode operation, and Dynamic (MIN/MAX/TIR — minimum / maximum / total indicator run-out).
- Individual or global foot switch mode operation.
- Bright red indicator lights for each input.
- Host command operation and setup.
- RS-232 output.
- Daisy chain multiple GageMux® units to connect up to 64 digital gages to a single RS-232 serial port.

Included Items

A complete GageMux® system includes the following items:

- GageMux®
- Operating manual
- Serial cable
- 9 volt DC power adaptor
- Phillips screwdriver

System Requirements

Before you begin to setup and install the GageMux® interface, we recommend that you first check to see that you have the following components:

- GageMux® gage interface.
- Computer with RS-232 serial port or other RS-232 serial device such as a serial printer.
- Standard RS-232 serial cable to connect GageMux® to external device (included).
- 9 volt power supply (included).
- One or more digital gages and matching cables.
- Phillips screwdriver (included).
- (Optional) Foot switch for gages without a send button.

GageMux® Quick Start

Below are diagrams that show the front and rear panels of the GageMux®.

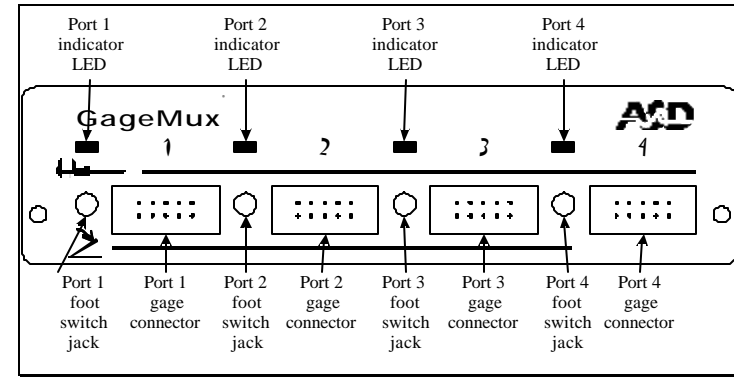

Figure 1; GageMux® Front Panel

The front panel has 4 ports. Each port has its own red indicator light, 2.5mm foot switch jack for a standard contact closure switch, and a 10-pin gage connector.

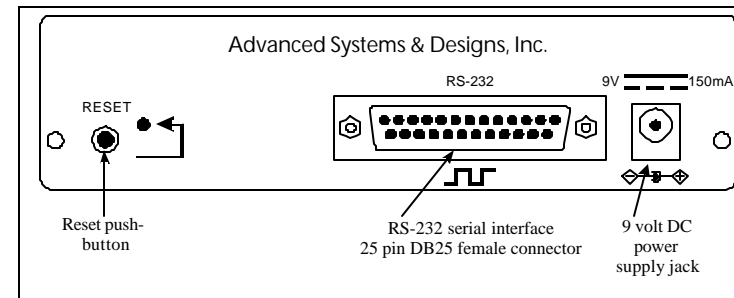

Figure 2; GageMux® Rear Panel

The rear panel has three components: The pushbutton reset switch, the 25 pin female D-type RS-232 serial connector, and the 9 volt power supply jack with the center pin negative.

Basic Operation

The basic operation of the GageMux® is straightforward. The following steps demonstrate the standard method to get it up and running:

1. Set the internal DIP switches (see the “Configuration and Setup” section below for details).
2. Connect the RS-232 cable to the GageMux®.
3. Connect the other end of the RS-232 serial cable to the serial device, i.e. computer or printer.
4. Connect your gages and foot switches to the GageMux®.
5. Connect the 9 volt DC power supply into the GageMux® and plug the power supply into a 110 volt AC outlet.
6. Press the reset button. The lights will flash and indicate which port has a gage connected.

You can now use your gages with the GageMux®. If you want to change a gage, use the following steps:

1. Disconnect and connect any gages as required.
2. Press the reset button.

Configuration and Setup

There are many ways to configure the GageMux®. The features that can be modified by DIP switch settings or host computer commands are:

- The output string format.
- The foot switch operation.
- Normal or MIN/MAX/TIR mode for each port.
- The channel number.
- The baud rate.

Descriptions and instructions for each setting are described below.

Output String Format

The GageMux® can be configured for three different output string formats. They are: reading only, full comma-delimited, and Mitutoyo Mux-10 format.

- **Reading Only Format**

In the reading only format, the output string will look like this:

```
SRRRRRRR<CR><LF>
+++++++
12345678
```

Where **RRRRRRR** is the reading and **S** is a space. It is followed by a carriage return and line feed. As an example, a gage with an output of -1.234mm would look like:

```
-1.2340<CR><LF>
+++++++
12345678
```

- **Full Comma-Delimited Format**

In the full comma-delimited format, the output string will look like this:

```

NNN, SRRRRRRRRR, MMM, SCC<CR><LF>
+++++
00000000011111111112222
12345678901234567890123
    
```

Where **NNN** is the reading number, **RRRRRRRRR** is the reading, **MMM** is the mode, (MIN, MAX, TIR, NRM), **S** is a space and **CC** is the channel number. It is followed by a carriage return and line feed. As an example, two consecutive readings from a gage with an output of -1.234mm plugged into Port 1 running in normal mode would look like:

```

001, -1.2340, NRM, 01
002, -1.2340, NRM, 01
+++++
00000000011111111112222
12345678901234567890123
    
```

- **Mitutoyo Mux-10 Format**

The Mitutoyo Mux-10 format consists of a string with up to 13 characters in it. It looks like this:

```

0CASRRRRRRRR<CR>
+++++
0000000001111
1234567890123
    
```

The first character is always **0**. **C** identifies the channel number. The third character is always **A**. **S** identifies the sign, which can be **+** or **-**. **RRRRRRRR** is the reading. As an example, a gage with an output of -1.234mm plugged into Port 1 would look like:

```

01A-001.2340<CR>
+++++
0000000001111
1234567890123
    
```

Foot Switch Operation

Described below are the modes of operation for the foot switch, Normal Foot Switch mode, Global Foot Switch mode, and Foot Switch Triggered mode.

- **Normal Foot Switch Mode**

Each input is controlled by its own foot switch or gage send button.

- **Global Foot Switch Mode**

In global foot switch mode, any time a foot switch or gage send button is activated, all available GageMux® inputs will be scanned for a reading. When multiple GageMux® units are daisy chained together, each GageMux® must be set in this mode for the port scanning to operate correctly.

- **Foot Switch Triggered Mode**

In this mode, any time a foot switch or gage send button is activated, the GageMux® does not send a data string. Instead, “**F<CR>**” (the letter f followed by a carriage return) is sent. This mode is most likely used when the GageMux® is under software application control. The GageMux® is still capable of sending data using host commands through the serial port. If an operator accidentally presses the foot switch, the application software will be aware that the foot switch was pressed but will not record a reading.

Normal and MIN/MAX/TIR Modes

The GageMux® can operate statically, or dynamically. When the GageMux® is operating statically, it is in Normal mode. When the GageMux® is operating dynamically, it is in MIN/MAX/TIR mode.

- **Normal Mode**

In Normal mode, each foot switch press or host request causes the GageMux® to request a single reading from the gage connected to the corresponding port.

- **MIN/MAX/TIR Mode**

In Dynamic mode, the first foot switch press or host request begins the scan of the gage. The second foot switch press or host request ends the scan and sends the MIN/MAX/TIR (minimum, maximum and total indicator run-out) values to the output.

Channel Number

The GageMux® can be daisy chained with other GageMux® units. In this situation, each additional GageMux® must be configured so that its ports do not conflict with the ports of other GageMux® devices. By assigning a different channel number to each port on the GageMux®, this conflict can be avoided.

For example, in a daisy chained configuration, the first GageMux® would be set up so that its ports numbered 1, 2, 3, 4 are assigned to channels 1, 2, 3, 4 respectively. The second GageMux® would be set up so that ports 1, 2, 3, 4, are assigned to channels numbered 5, 6, 7, 8 respectively. When a gage is connected to port 3 of the second GageMux®, its data would be output on channel 7.

Flow Mode

The GageMux® can also be operated in flow mode. When in this mode, all ports are continuously scanned and readings from active ports are output in the full comma-delimited format.

DIP Switch Settings

The tables below give the correct DIP switch settings for all modes of operation.

To access the internal DIP switch banks, follow these instructions:

1. Remove the rear cover. Use a Philips screwdriver (included) to unscrew the two Philips screws located on the rear of the enclosure. Pull off the rear faceplate and bezel.
2. Remove the top. Gently slide the top of the enclosure toward the rear to expose the inside of the GageMux®.

The DIP switch banks are labeled DIPSW1, DIPSW2, and DIPSW3 from left to right when looking at them from the rear and each switch is numbered 1 through 4. (See Figure 3).

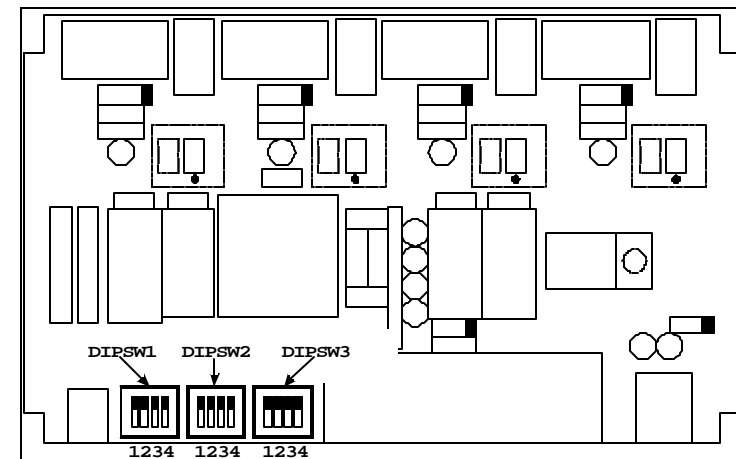
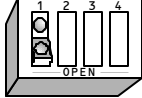
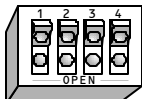
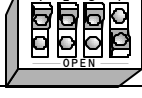
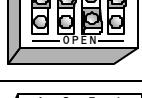
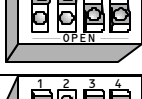
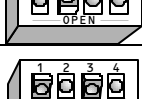
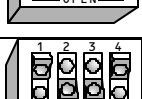
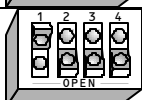
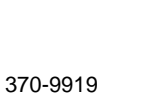

Figure 3; DIP Switch Locations

**Note: The Factory default settings are for normal foot switch mode, full output string, 9600 baud, all gages in normal mode, and channel numbers set to 1, 2, 3, and 4.*





DIPSW1

- Switches 1, 2, 3, and 4—Settings for Flow Mode, Foot Switch, Output String Formats, and Baud Rate

DIPSW1					
Description	Switch 1	Switch 2	Switch 3	Switch 4	
Flow mode, Full comma delimited format, 9600 baud, Switch 1 overrides 2, 3, and 4	Closed	Open or Closed	Open or Closed	Open or Closed	
Normal foot switch mode, Full comma delimited format, 9600 Baud	Open	Open	Open	Open	
Normal foot switch mode, Reading only format, 9600 Baud	Open	Open	Open	Closed	
Normal foot switch mode, Mitutoyo Mux-10 format, 9600 Baud	Open	Open	Closed	Open	
Global foot switch mode, Full comma delimited format, 9600 Baud	Open	Open	Closed	Closed	
Global foot switch mode, Reading only format, 9600 Baud	Open	Closed	Open	Open	
Global foot switch mode, Mitutoyo Mux-10 format, 9600 Baud	Open	Closed	Open	Closed	
Foot switch triggered mode	Open	Closed	Closed	Open	
Normal foot switch mode, Reading only format, 4800 Baud	Open	Closed	Closed	Closed	

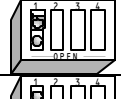
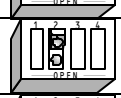
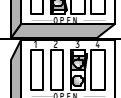
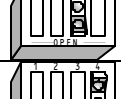
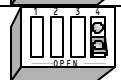
DIPSW2

- Switches 1, 2, 3, 4—Normal or MAX/MIN/TIR Mode

DIPSW2					
Description	Switch 1	Switch 2	Switch 3	Switch 4	
Port 1 Normal Mode	Open	---	---	---	
Port 1 Max/Min/Tir	Closed	---	---	---	
Port 2 Normal Mode	---	Open	---	---	
Port 2 Max/Min/Tir	---	Closed	---	---	
Port 3 Normal Mode	---	---	Open	---	
Port 3 Max/Min/Tir	---	---	Closed	---	
Port 4 Normal Mode	---	---	---	Open	
Port 4 Max/Min/Tir	---	---	---	Closed	

DIPSW3

- Switches 1, 2, 3, 4—Channel Settings for Multiple Daisy Chained GageMux® Devices

DIPSW3						
GageMux® Number	Channel	Switch 1	Switch 2	Switch 3	Switch 4	
1	01-04	Open	Open	Open	Open	
2	05-08	Closed	Open	Open	Open	
3	09-12	Open	Closed	Open	Open	
4	13-16	Closed	Closed	Open	Open	
5	17-20	Open	Open	Closed	Open	
6	21-24	Closed	Open	Closed	Open	
7	25-28	Open	Closed	Closed	Open	
8	29-32	Closed	Closed	Closed	Open	

DIPSW3 Continued						
GageMux® Number	Channel	Switch 1	Switch 2	Switch 3	Switch 4	
9	33-36	Open	Open	Open	Closed	
10	37-40	Closed	Open	Open	Closed	
11	41-44	Open	Closed	Open	Closed	
12	45-48	Closed	Closed	Open	Closed	
13	49-52	Open	Open	Closed	Closed	
14	53-56	Closed	Open	Closed	Closed	
15	57-60	Open	Closed	Closed	Closed	
16	61-64	Closed	Closed	Closed	Closed	

* Note:

Whenever you change the DIP switches settings in order to reconfigure the GageMux® interface, the new settings will not take effect until the reset button is pressed or power is removed and replaced.

Host Commands

The GageMux® interface will accept various commands from the host computer to change channel setups or request data from gages. The following is a list of the commands and their formats. Note that any change to an input channel's mode using host commands takes effect immediately, and lasts until the mode is changed from the host, the reset button is pressed (modes are always reset to DIP switch settings), or power is removed.

Command	Description	Example
RCC<CR>	Read data from a channel. CC is the channel number (01 through 64) and <CR> is a carriage return (Enter).	R01<CR> Requests data from channel #1
SCCM<CR>	Change the setup of a channel. CC is the channel number (01 through 64). M is the mode (0 for Normal mode, 1 for MIN/MAX/TIR mode). <CR> is a carriage return (Enter).	S101<CR> Changes the mode of channel 10 to MIN/MAX/TIR.
OM<CR>	Change the output string mode. M is the mode (0 for full comma delimited output string mode, 1 for reading only mode, 2 for Mitutoyo Mux-10 mode). <CR> is a carriage return (Enter).	O0<CR> Changes the output mode to full comma delimited.
FM<CR>	Change the foot switch mode. M is the mode (0 for normal foot switch mode, 1 for global foot switch mode). <CR> is a carriage return (Enter).	F1<CR> Changes the foot switch mode to global.
XX<CR>	Reset the GageMux® as if the reset button were pressed. <CR> is a carriage return (Enter).	XX<CR> Reset the GageMux®.

Warranty

The quality of this product is warranted for a period of 12 months from the date of purchase. This warranty covers all material and manufacturing defects. Advanced Systems & Designs, Inc. shall repair, or if deemed necessary, replace a defective unit free of charge for the duration of the warranty. An RMA form must accompany all repairs or returns. Please call (248) 370-9919 to receive an RMA form.

Tech Support

Our technical support staff is available to solve any problems related to this product. Please contact us through the internet at support@asdspc1.com, or by phone at (248) 370-9919, or by fax at (248) 370-9921.

Revision History

Version	Date	Description
1.0	November, 1999	Updated manual to match GageMux® 100-40P-F